



HEAT PUMPS

Commercial and residential
energy-efficient hot water



Suitable for residential and commercial use

Australian energy-efficiency schemes encourage both households and businesses to install energy-efficient products.

Generous certificate rebates are available to incentivise homes and businesses to adopt smart technology solutions to help reduce their carbon footprint.



AUSTRALIAN ENERGY SAVING SCHEMES

Australian federal, state and territory governments have established energy-efficiency schemes to incentivise the adoption of smart technology solutions to help reduce energy usage and the carbon footprint of businesses and households across the country.

Emerald works closely with government agencies to ensure our products are at the forefront of energy-efficient technology, and aligned to the benchmarks set by the energy-efficiency schemes across Australia. Our hot water heat pumps are approved for installation within multiple government schemes.

HIGH SMALL-SCALE TECHNOLOGY CERTIFICATES (STC)

Air source heat pumps qualify for Small-Scale Technology Certificates (STCs) that encourage heat pump water heater installation. STCs can be traded on the Australian market based on their value, which is determined by the efficiency of the unit and the temperature zone in Australia. Each STC represents 1MWh of energy saved over ten years.



PEAK DEMAND REDUCTION SCHEME (PRC)

A Peak Reduction Certificate is a tradeable certificate created when an Accredited Certificate Provider undertakes activities that provide the capacity to reduce electricity usage during peak demand periods.



EMERALD'S RANGE OF QUALITY HEAT PUMPS

200L and 300L models are available with an optional built-in electric heater as backup for faster heating to ensure continuous hot water supply in cold weather conditions.



RESIDENTIAL:
COMMERCIAL:



EE-HWS-RCHP-200
EE-HWS-RCHP-200-1



EE-HWS-RCHP-200E
EE-HWS-RCHP-200E-1
(with backup electric heater)



EE-HWS-RCHP-300
EE-HWS-RCHP-300-1



EE-HWS-RCHP-300E
EE-HWS-RCHP-300E-1
(with backup electric heater)

REFRIGERANT CYCLING HEAT PUMP - 200L AND 300L

OPTIMISED FOR ENERGY-EFFICIENCY

The heat pump's micro channel heat exchanger is located in the water tank, driving improved energy-efficiency.

OPTIONAL BUILT-IN ELECTRIC HEATER

Both models are available with an optional built-in back up electric heater.

BLUE DIAMOND ENAMEL TANK

Ensures the surface is clean and smooth - reducing dust from adhering.

WARRANTY

7 years tank.

5 years heat pump unit.

2 years labour warranty.

**Subject to terms and conditions*



HEALTH AND COMFORT

HIGH WATER TEMPERATURE AND LARGE WATER TANK DESIGN

200L and 300L big volume design ensure multi-point simultaneous use during peak water consumption.

ANTI-LEGIONELLA FUNCTION

Disinfection temperature 60~75°C

Unit without electric heater:

Maximum disinfection temperature 65°C

Unit with electric heater:

Maximum disinfection temperature 75°C

Two disinfection modes available:

Periodicity automatically disinfect

Manually disinfect

SPLIT SYSTEM DESIGN

Due to the split design, the water tank can be placed close to where the hot water will be used - the hot water pipe is shorter for a quicker hot water supply.

The longer refrigerant piping allows the outdoor unit to be placed further away from living areas, minimising any noise impact.

Maximum. piping length: 20m

Maximum. piping difference in height: 10m

BLUE DIAMOND ENAMEL TANK

Blue Diamond enamel technology ensures the surface is clean and smooth and reduces dirt from adhering - keeping the tank cleaner and more hygienic over time.

SAFETY FEATURES

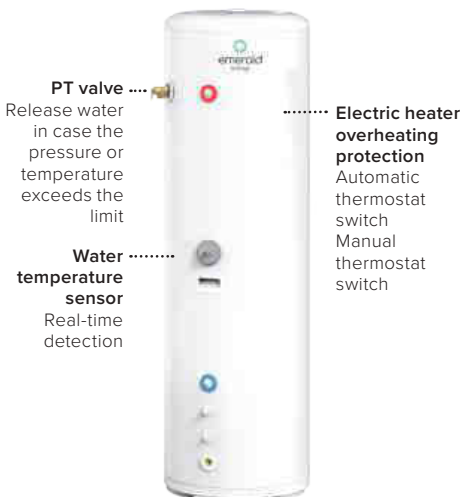

PRECISE TEMPERATURE AND PRESSURE CONTROL



Current protection



High pressure protection



Discharge temperature protection



Superheat protection



Anti-freezing protection



ANTIFREEZE CONTROL

PRODUCT DIMENSIONS

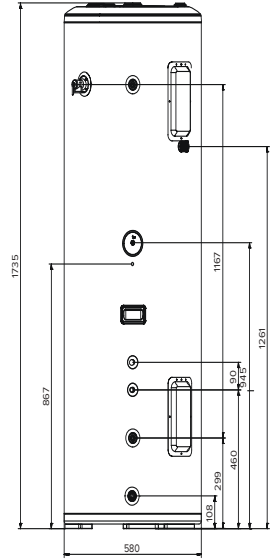
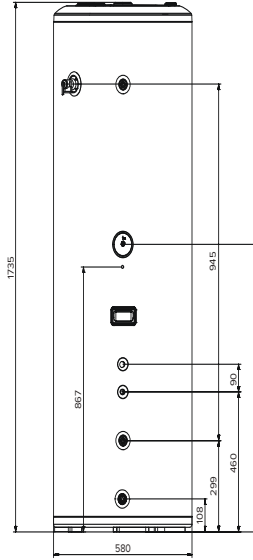
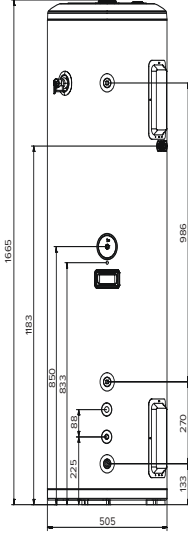
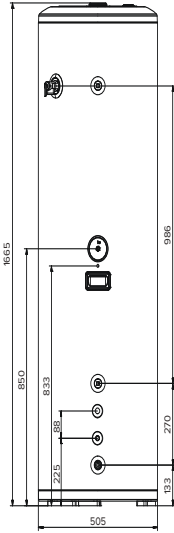
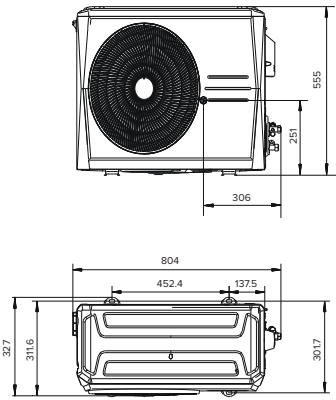

RESIDENTIAL: EE-HWS-RCHP-200
COMMERCIAL: EE-HWS-RCHP-200-1

EE-HWS-RCHP-200E
EE-HWS-RCHP-200E-1
(with backup electric heater)

EE-HWS-RCHP-300
EE-HWS-RCHP-300-1

EE-HWS-RCHP-300E
EE-HWS-RCHP-300E-1
(with backup electric heater)

SYSTEM DIAGRAM

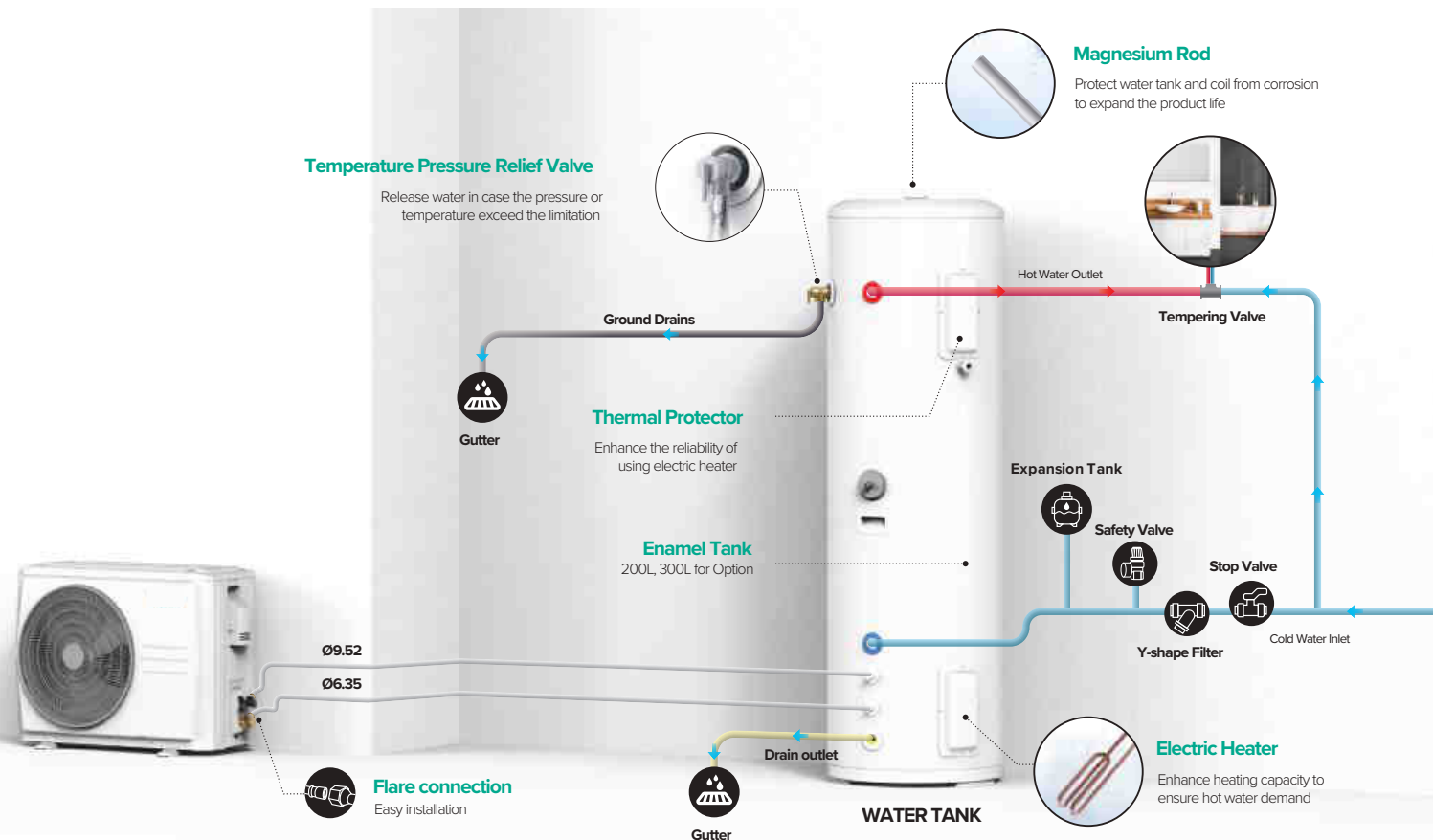

SPECIFICATIONS

	MODEL NUMBER		EE-HWS-RCHP-200	EE-HWS-RCHP-200E	EE-HWS-RCHP-300	EE-HWS-RCHP-300E	
			EE-HWS-RCHP-200-1	EE-HWS-RCHP-200E-1	EE-HWS-RCHP-300-1	EE-HWS-RCHP-300E-1	
GENERAL	Ambient temperature		°C		-15~46		
	Leaving water temperature		°C		20~63		
	Heating	Capacity ₁	W	2600			
		Input	W	1000			
	Hot water yield		m ³ /h	0.044 ¹ / 0.056 ²			
	Refrigerant piping	Refrigerant piping	mm(inch)	Ø6.35 / Ø1/4'			
		Gas side	mm(inch)	Ø9.52 / Ø3/8'			
		Max. height difference	m	10			
		Max. refrigerant pipe length	m	20			
	Design pressure		MPa	3			
OUTDOOR UNIT	Outdoor unit power supply		V/N/Hz		220-240/1/50		
	Max. current		A	4.4	13.5	4.4	13.5
	Compressor		Type	Rotary			
	Fan	Type		AC			
		Air flow (H/L)	m ³ /h	1250/769			
	Air side heat exchanger		Type	Hydraulic aluminum fin + Inner grooved copper tube			
	Throttle		Type	Electric expansion valve			
	Outdoor sound pressure level		dB(A)	54			
	Dimension	Unit dimension (L*W*H)	mm	804*327*555			
		Packing dimension (L*W*H)	mm	845*390*610			
		Net weight	kg	29			
		Gross weight	kg	32			
	Refrigerant	Type		R134a			
		Charged volume	g	900			
INDOOR UNIT	Tank volume		L	200	200	300	300
	Electric heater	Capacity	kW	/	2.1	/	2.1
		Power supply	V/N/Hz	220-240/1/50	220-240/1/50	220-240/1/50	220-240/1/50
	Dimension	Unit dimension(W*D*H)	mm	505*505*1665	505*505*1665	580*580*1735	580*580*1735
		Packing dimension(W*D*H)	mm	1775*635*590	1775*635*590	1835*690*670	1835*690*670
		Net weight	kg	73	73	96	96
		Gross weight	kg	83	83	108	108

1. Ambient temperature 19/15°C(DB/WB), Initial water temperature 9°C, Terminative water temp. 60°C.

